

## Circuit Breakers

Circuit breakers are used in panelboards and switchboards to provide circuit protection and provide a means of energizing and de-energizing a circuit. Siemens Sentron molded case circuit breakers (MCCB) used in panelboards are available with current ratings from 15 to 1200 amps.

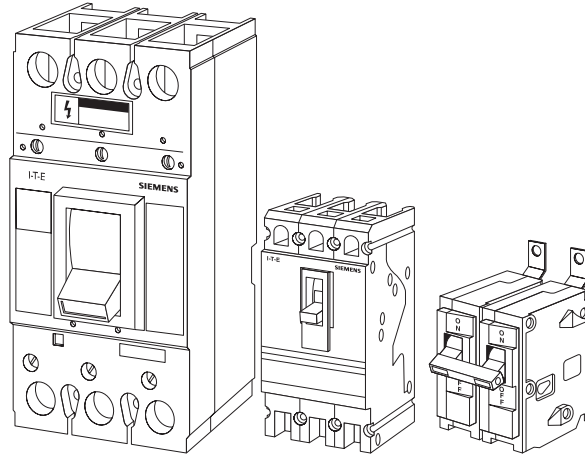

Sentron series molded case circuit breakers used in switchboards are available up to 2000 amps. Siemens encased systems breakers are generically called insulated case circuit breakers (ICCB). Siemens insulated case circuit breakers are available with current ratings up to 5000 amps.

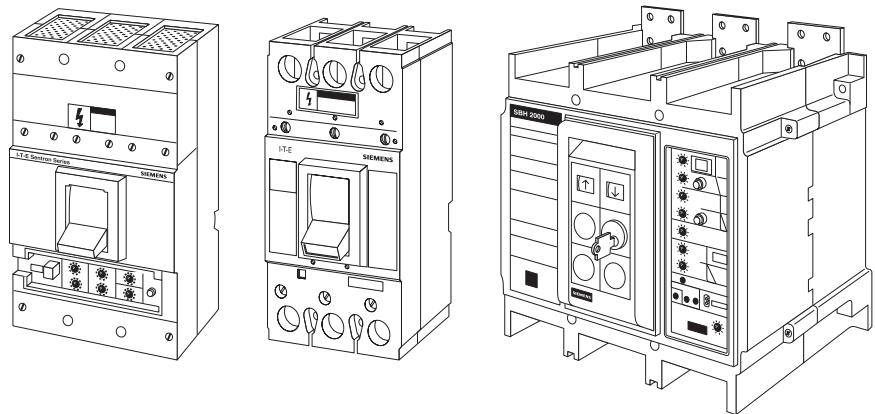

Sentron Series  
Sensitrip III MCCB

Sentron Series MCCB

Insulated Case Circuit Breaker (ICCB)

## Fusible Disconnect Switch

A fusible disconnect switch is another type of device used in panelboards and switchboards to provide overcurrent protection. Properly sized fuses located in the switch open when an overcurrent condition exists. Siemens fusible switches are available with ampere ratings from 30 to 1200 amps.

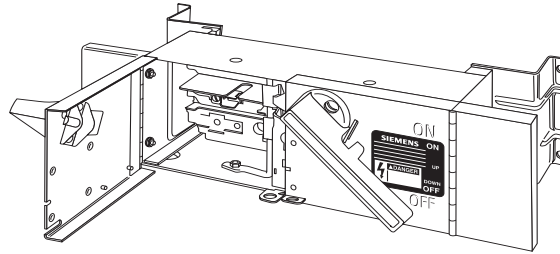

## Bolted Pressure Switches

Bolted pressure switches are also used in switchboards as main disconnects. Bolted pressure switches are available in ratings up to 4000 amps.

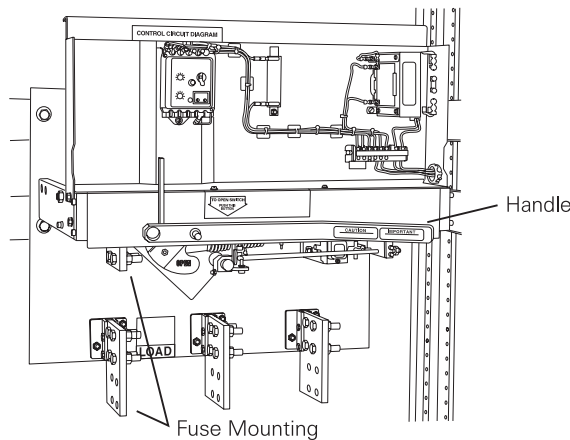

## Type RL Circuit Breaker

Siemens RL series low voltage power circuit breakers can also be used in Siemens switchboards. RL series circuit breakers are designed with current carrying capacities up to 5000 amps.

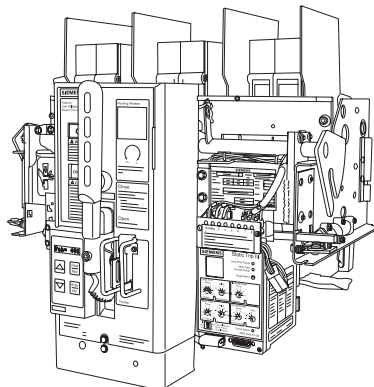

## Meters

Siemens offers a full line of power meters for use in the service section of switchboards. Meters can be used to measure real-time RMS (root-mean-square) values of phase currents, phase and line voltages, power usage, power factor, and peak demand. In addition, Siemens also has meters capable of monitoring power quality, such as K-factor, crest factor, individual harmonics, and total harmonics. Meters such as the 9350 and 9600 can act as a Web server. When combined with an Ethernet port, these meters offer quick and easy access to monitored values without the need for special software.

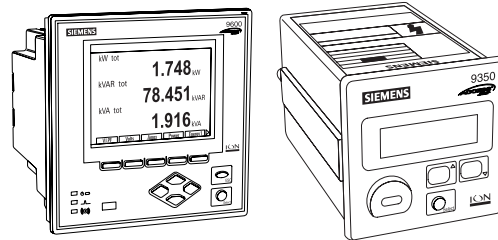

9600

9350

## ACCESS™

Siemens meters have communication capability using the Siemens ACCESS system software. Siemens ACCESS is more than just power meters and other hardware. The ACCESS power management and control system is a networked system comprised of a variety of devices that monitor and control an electrical distribution system. The ACCESS system provides electrical data necessary for troubleshooting, power quality studies, preventative maintenance, and cost allocation. A power monitoring and management system, such as Siemens ACCESS, can identify potential problems before they cause costly breakdowns.

Here are just five benefits to using the ACCESS system.

- Reduce or eliminate unplanned outages
- Proactively manage power systems to minimize utility bills
- Automate allocation of utility power bills
- Optimize existing capital equipment used in power systems
- Record and analyze power quality and power system anomalies



## TPS

Computers and other office equipment are susceptible to the high energy levels caused by an electrical surge, whether it is caused by electrical equipment or lightning. Any component between the source of the surge and ground can be damaged. One option available to protect equipment from electrical surges is the Siemens TPS (transient protection system). The TPS clamps voltage spikes before they damage expensive and sensitive equipment. Siemens TPS can be used with busway, panelboards, and switchboards.

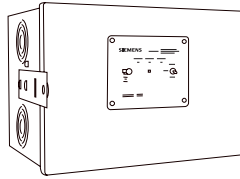

Busway TPS

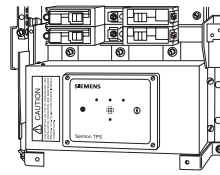

TPS Mounted in  
S1 Panelboard

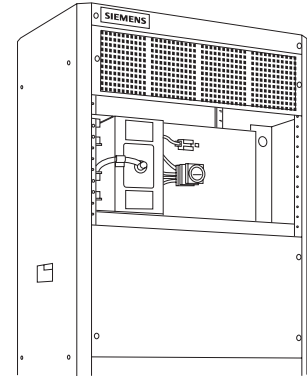

TPS Mounted in  
SB3 Switchboard

## AC Motors

AC motors, such as the Siemens Medallion™ motors, can be found in a variety of applications in commercial buildings. Siemens Medallion EPACT efficiency motors are high performance motors designed to meet the requirements of the U.S. Energy Policy Act of 1992 (EPAAct). EPACT efficiency motors are available from 1 to 200 HP.

Siemens Medallion PE-21 Plus motors are premium efficiency motors available from 1 to 500 HP. Premium efficiency motors typically cost slightly more than standard efficiency motors, but payback is in energy savings.

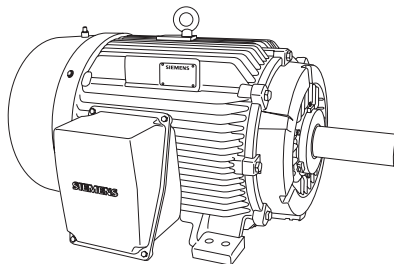

Motors can be found on fans, pumps, elevators, escalators, and conveyors. A small conveyor, for example, might be used in a department store to move packages from a storeroom to a customer pickup location.

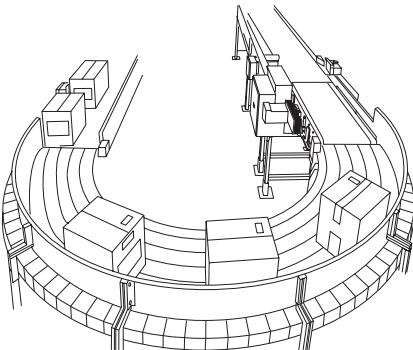

**Safety Switches**

Safety switches provide a means for a service entrance or a disconnecting means and fault protection for motors. A safety switch is simply a switch located in its own enclosure. The enclosure provides a degree of protection to personnel against incidental contact with live electrical equipment. Safety switches are available with or without provisions for fuses. Siemens enclosed switches are available with current ratings from 30 amps to 4000 amps.

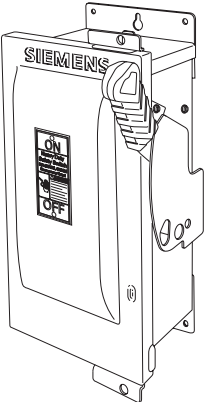

Heavy Duty



General Duty

## Motor Starter

Although safety switches can be used to start and stop motors, many motor applications require the use of remote control devices to start and stop the motor. Motor starters are commonly used to provide this function. Some motor starters have multi-speed and reversing capability.

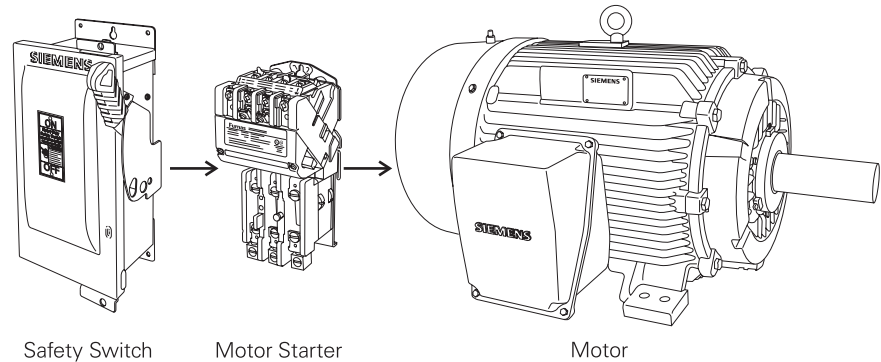

A motor starter consists of a magnetic contactor and an overload relay. The contactor is an electromagnetic device used to close and open a set of contacts, which starts and stops the connected motor. If an overload occurs, excessive heat can build up in a motor which can damage the motor's winding insulation. The overload relay will automatically stop the motor in this event.

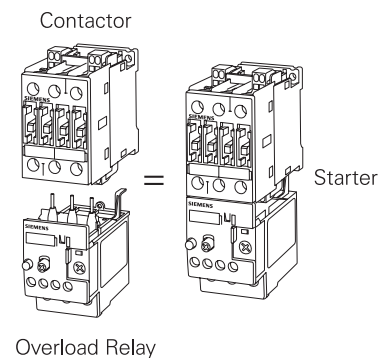

Siemens manufactures a variety of starters, such as the Furnas INNOVA PLUS and the Furnas ESP100.

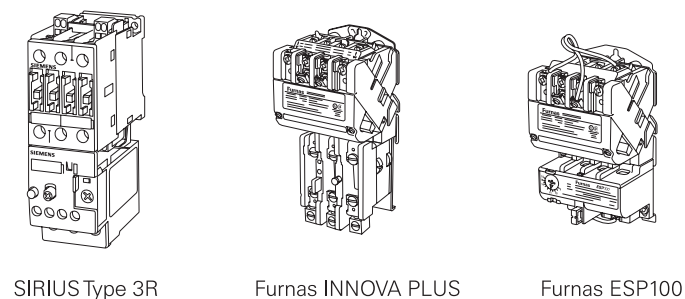

## Review 2

1. \_\_\_\_\_ may be accessible from the rear as well as the front?
  - a. Load Centers
  - b. Panelboards
  - c. Switchboards
  - d. All the Above
2. \_\_\_\_\_ is a system manufactured by Siemens to provide protection in panelboards, switchboards, and busway from electrical surges.
3. Switchboards typically consist of a service section and one or more \_\_\_\_\_ sections.
4. The \_\_\_\_\_ commercial metering switchboards are designed to meet west coast utility specifications.
5. Siemens safety switches are available with current ratings from 30 to \_\_\_\_\_ amps.

# Industrial Applications

## Voltage Classes

Electrical power requirement is a major consideration in industrial applications. Typically voltage is received and distributed at much higher levels than residential and commercial applications. Equipment must be specially designed to receive high transmission voltage from a utility company, and effectively distribute it throughout the industrial facility. Industrial facilities typically make large demands on the electrical utility, making it impractical to supply voltage at lower levels. The level of voltage supplied by the utility company varies with the requirements of the facility. For discussion purposes, it is sometimes convenient to divide voltages into classes. The Institute of Electrical and Electronics Engineers (IEEE), for example, divides voltage systems into the following classes:

<b>Low-Voltage Systems</b>	<b>Medium-Voltage Systems</b>	<b>High-Voltage Systems</b>	<b>Extra-High-Voltage (EHV) Systems</b>
1000 volts or Less	Greater than 1000 volts to 100,000 volts*	Greater than 100,000 volts to 230,000 volts	Greater than 240,000 volts to 800,000 volts

\*Most medium-voltage systems are rated at 38,000 volts or less.

Since the voltages supplied to the industrial facilities are typically either low or medium voltages, this discussion will focus on low and medium voltage systems beginning with a discussion of switchgear.

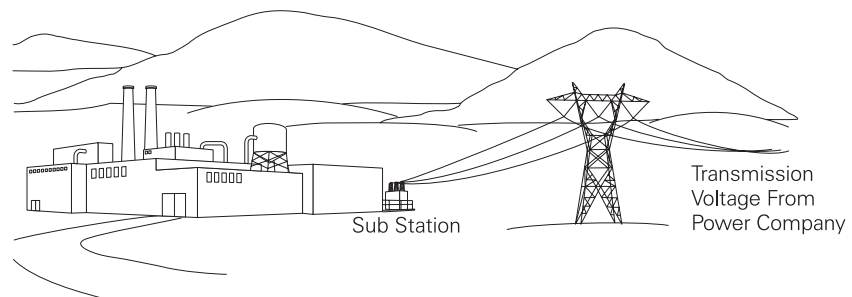



## Switchgear

The term switchgear is used to describe coordinated devices used for control and protection of equipment such as generators, transformers, capacitor banks, motors, and distribution lines. Switchgear is accessible from the front and rear. Siemens manufactures switchgear for low- and medium-voltage applications.

## Medium-Voltage Switchgear

Medium-voltage switchgear normally conforms to design requirements for metal-clad switchgear. Siemens manufactures medium-voltage switchgear rated at various levels to meet the requirements of typical medium-voltage applications found in many industrial facilities.

## 38 kV Switchgear

Siemens 38 kV medium-voltage, metal-clad switchgear is rated for voltages between 16.5 kV (16,000 volts) and 38 kV (38,000 volts). Siemens metal-clad switchgear features 38-3AF circuit breakers which are available in 1200, 2000, and 3000 amp current ratings.

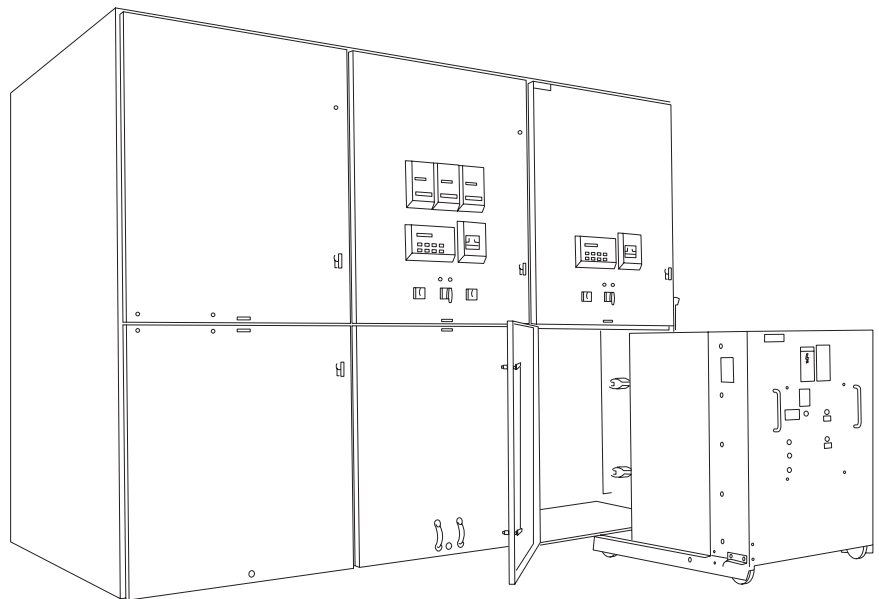

## 5 - 15 kV Switchgear

Siemens 5 - 15 kV metal-clad switchgear is designed to handle voltages of 4.16 kV (4160 volts), 7.2 kV (7200 volts), and 13.8 kV (13,800 volts). Siemens 5 - 15 kV switchgear features vacuum circuit breakers rated for 1200, 2000, and 3000 amps.

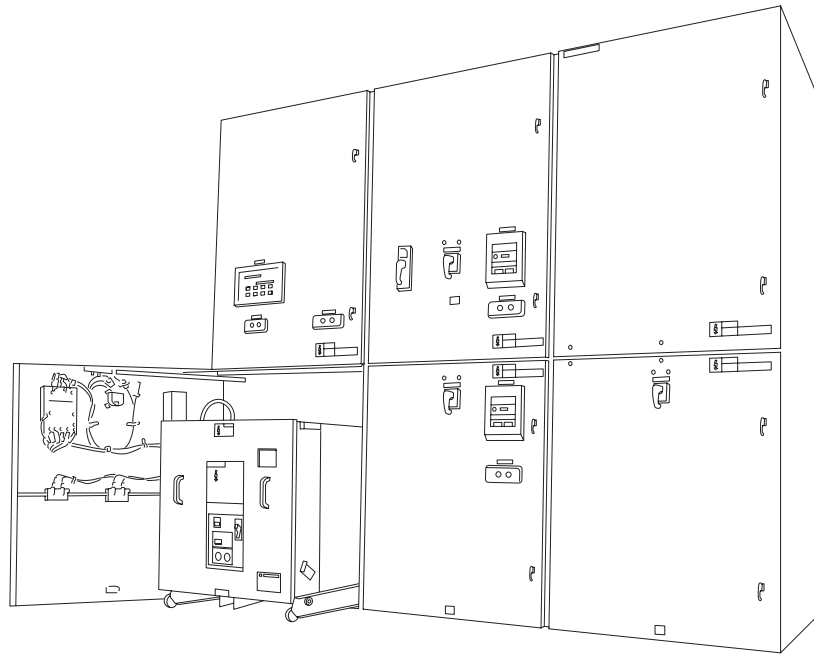

## NXAIR P

NXAIR P medium voltage switchgear is "arc vented." This design handles arc fault events more safely by directing expanding gases of an arc fault up and away from the operator. NXAIR P meets American standards (ANSI) and international standards (IEC) for global compliance. NXAIR P handles voltages from 5 kV to 15 kV with vacuum type circuit breakers rated from 1200 amps to 4000 amps.

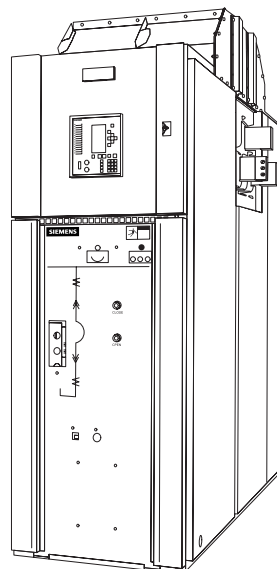

## Medium-Voltage Switchgear Example

A large industrial facility, such as a paper or steel mill, receives electrical power at a substation from the utility company at high transmission voltage levels. The voltage is stepped down to a medium-voltage level at the substation for distribution by the industrial facility. Large industrial facilities can be spread out over several acres and incorporate many large buildings. Exact power distribution will depend on machinery location and power requirements. Multiple medium-voltage, metal-clad switchgear units could be used if the facility and the power demand were large enough.

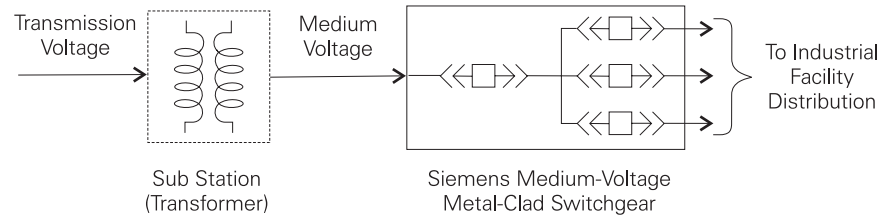

It can be seen in this example that one 38 kV metal-clad switchgear unit is supplying power to two 5 kV metal-clad switchgear units and one 15 kV metal-clad switchgear unit. This is one way power might be distributed throughout a large industrial complex made up of several buildings, each requiring great amounts of electrical power.

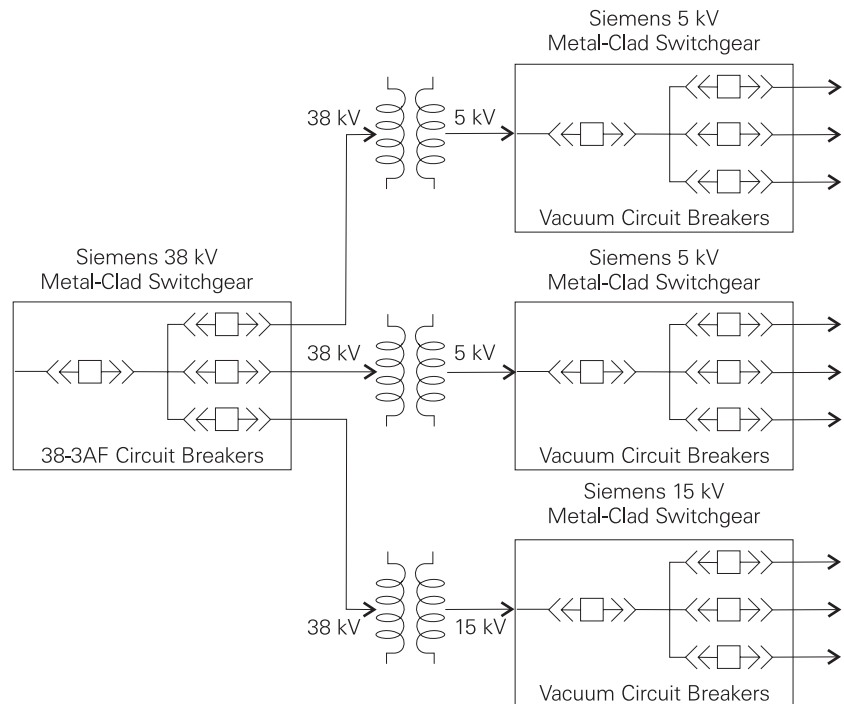

## Low-Voltage Switchgear

Low-voltage switchgear normally conforms to the design requirements for metal-enclosed switchgear. Siemens low-voltage switchgear can be used on distribution systems with 208, 240, 480, or 600 volts with currents up to 5000 amps in the Type R (indoor) and 4000 amps in the Type SR (outdoor). TPS (transient protection system) is available for Type R, low voltage switchgear applications.

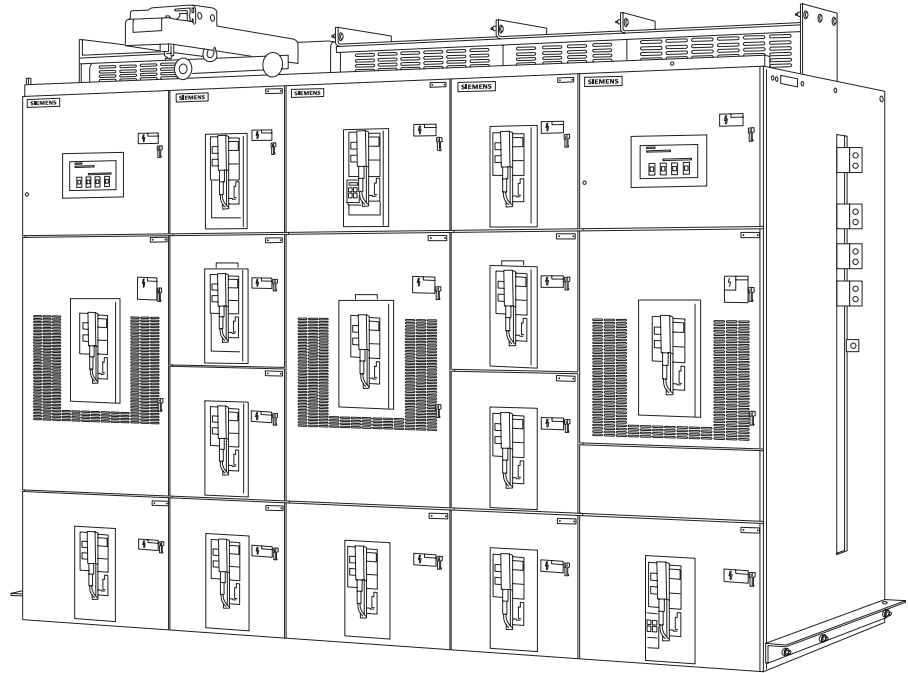

## Type RL Circuit Breaker

Siemens RL series low voltage power circuit breakers are used in the Siemens low voltage switchgear. RL series circuit breakers are designed for up to 600-volt service with current carrying capacities up to 5000 amps.

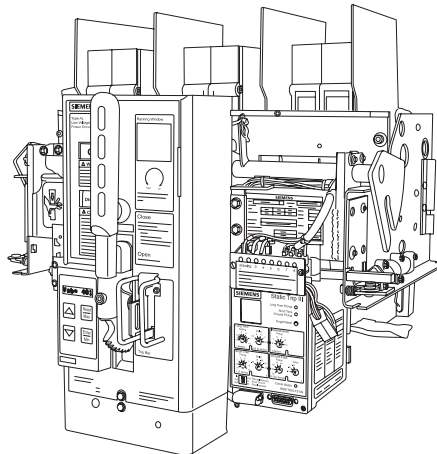

## Secondary Unit Substation

Another method used to handle distribution voltage is with a secondary unit substation.

A typical secondary unit substation consists of three sections which are coordinated in design to form one uniform enclosure.

1. An incoming section that accepts incoming voltage and may include a primary switch.
2. A transformer section that transforms incoming voltage down to a utilization voltage.
3. An outgoing section that distributes power to outgoing feeders and provides protection for these feeders.

A primary switch is used to provide a means to connect and disconnect the secondary unit substation from the supply service. The transformer section can be liquid filled, ventilated dry type, or a cast-coil type. The outgoing section can be a Siemens Sentron switchboard, such as the RCIII, or Type R low-voltage switchgear.

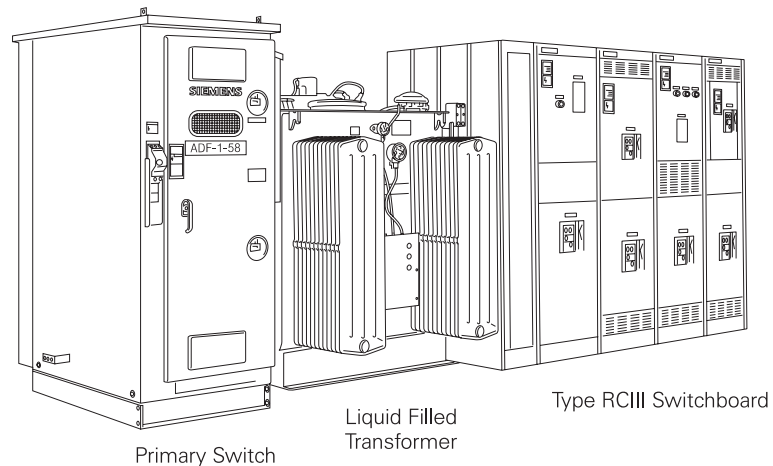

## Small Industrial Facility

A small industrial facility might use a distribution scheme similar to the one shown below. In this example, transmission voltage is stepped down to 15 kV and applied to the input of the facility's secondary unit substation. The transformer located in the substation steps the voltage down to 480 volts where it is distributed to various switchboards and panelboards.

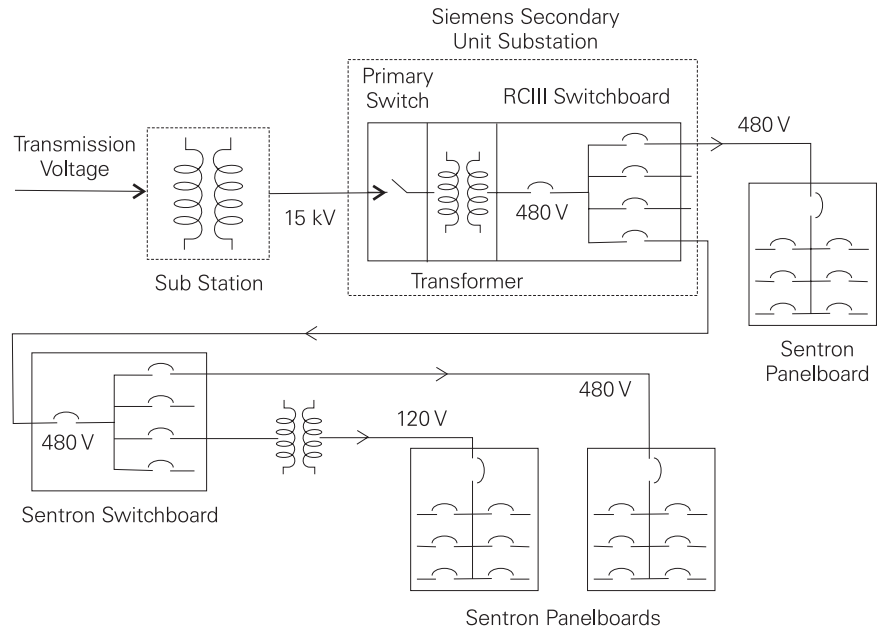

## Large Industrial Facility

A large industrial facility might use a power distribution scheme similar to the one shown below. In this application power is received at the industrial facility's substation where it is stepped down to 38 kV for distribution. The distribution voltage is applied to the input of a 38 kV medium-voltage, metal-clad switchgear unit. One distribution branch is stepped down to 15 kV and applied to the input of a 15 kV switchgear unit. One of the outputs of the 15 kV switchgear is applied to the input of a secondary unit substation which uses low-voltage switchgear to distribute 480 volts throughout one section of the facility. The other outputs of the various switchgear units can be used to similarly distribute power.

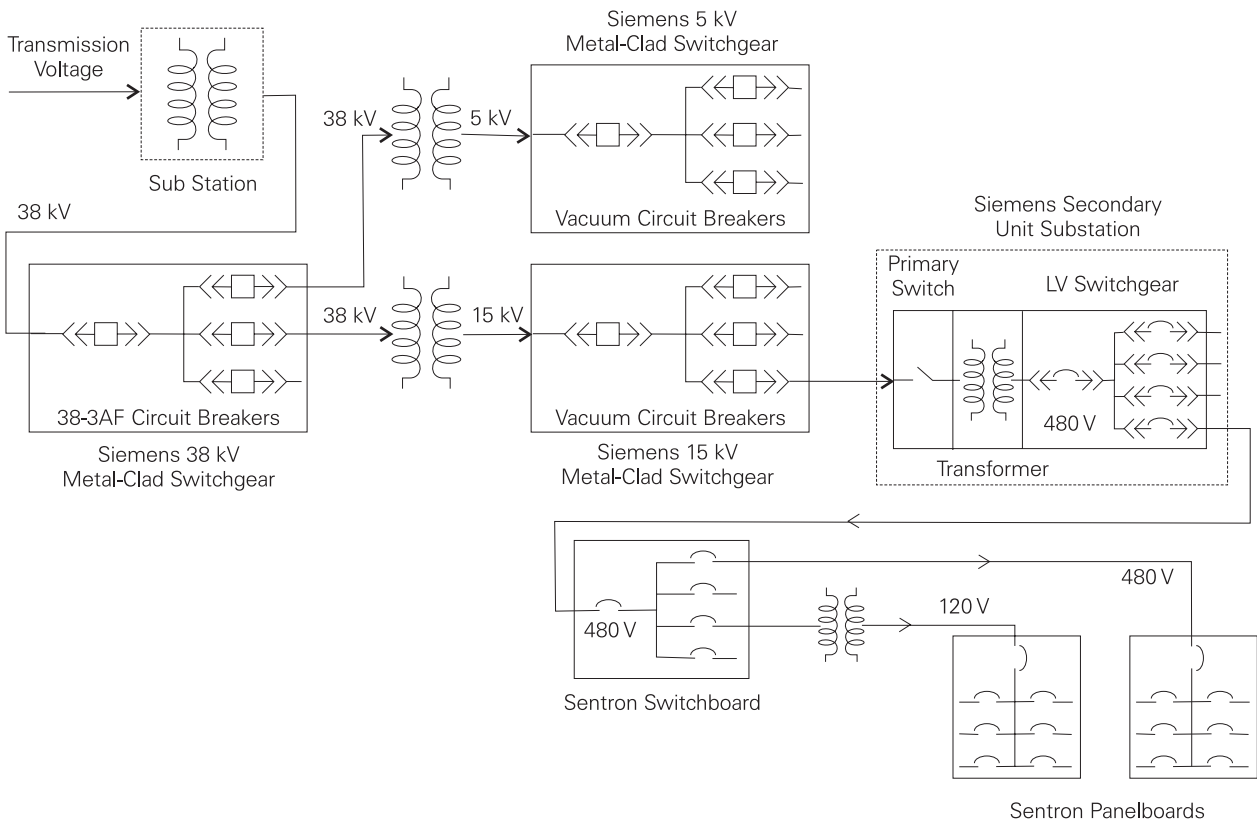

## Busway

Even in large industrial facilities supply voltage must be reduced to a level that can be used by most electrical equipment. AC motors, drives, and motor control centers, for example, typically operate on 480 volts. General lighting and electrical receptacles operate on 120 volts. Busway is widely used in industrial applications to distribute this electrical power.

## Types of Busway

Feeder busway is used to distribute power to loads that are concentrated in one physical area. Industrial applications frequently involve long runs from the power source to a single load. This load may be a large machine, motor control center, panelboard, or switchboard. Feeder busway sections are available in 0.125" increments from 2' to 10'.

Plug-in busway is used in applications where power requirements are distributed over a large area. Using plug-in units, load connections can be added or relocated easily. Sentron™ plug-in busway is available in 4', 6', 8', and 10' lengths.

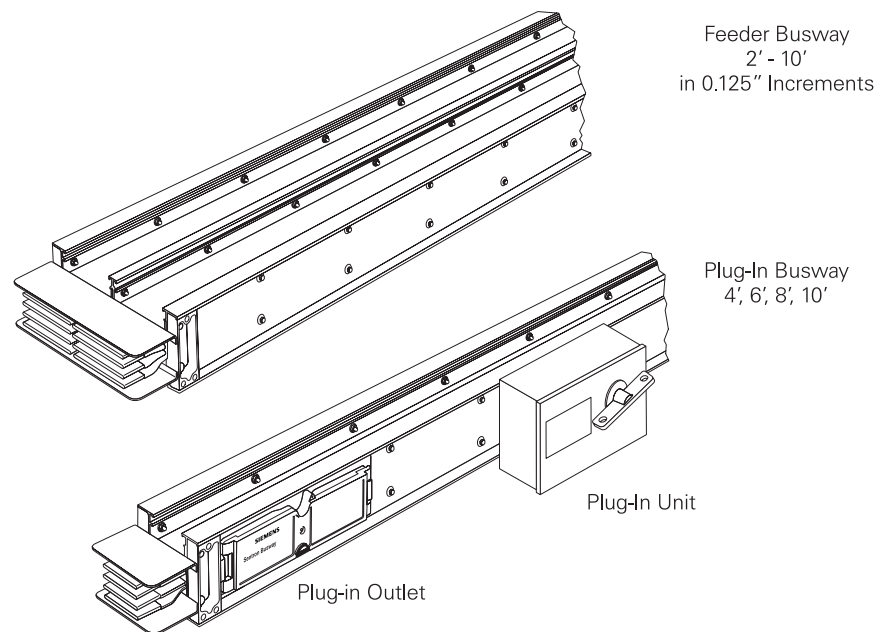



Busway runs also include a number of components such as tees, offsets, and elbows used to route busway through the facility.

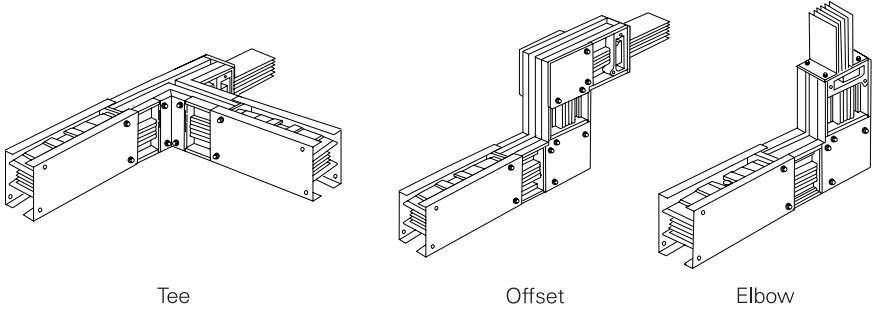

**Busway Example**

In this example, busway is used to transfer power from switchgear located outside a building to a switchboard located inside a building. Electrical power is then distributed to various locations in the industrial facility. Siemens Sentron busway is available with current ratings up to 5000 amps at 600 volts.

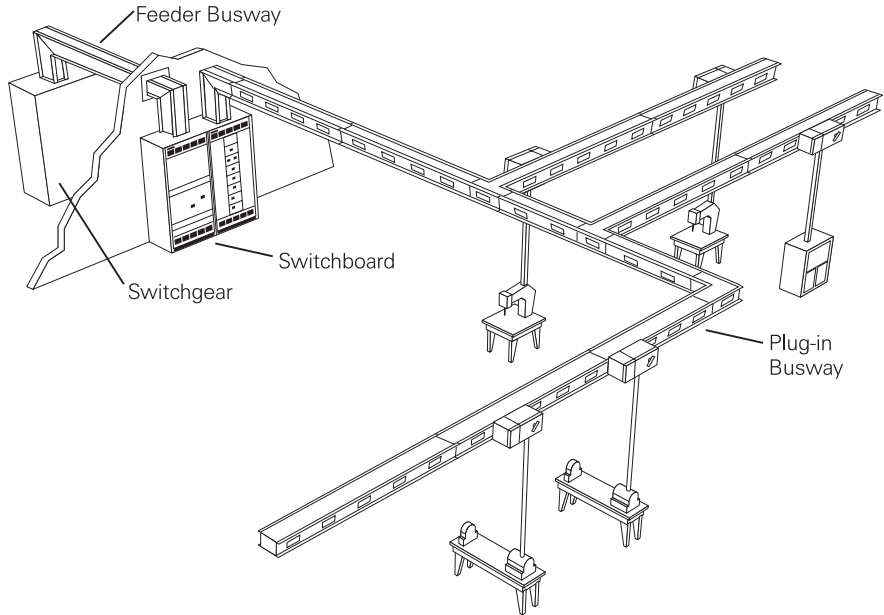

### Review 3

1. Voltages less than 1000 volts are classed as \_\_\_\_\_ voltage.
2. Siemens 38 kV medium voltage, metal-clad switchgear is rated between \_\_\_\_\_ kV and 38 kV.
3. Siemens type \_\_\_\_\_ low voltage switchgear can be used outdoors.
4. The \_\_\_\_\_ section of a secondary unit substation transforms incoming voltage down to a utilization voltage.
5. \_\_\_\_\_ busway is used to distribute power to a single load that is located a long way from the power source.